



Renlita Float Owner's **Manual**

Owner's Manual for the Float Renlita Door

Congratulations on your purchase of a new Renlita door.

We have specially engineered your door for your design, and we are confident that your robust, sleek Renlita door will provide you with many years of enjoyment.

We pride ourselves in satisfying customers, so please contact us if you are not satisfied with your door so that we can do everything to make it right.

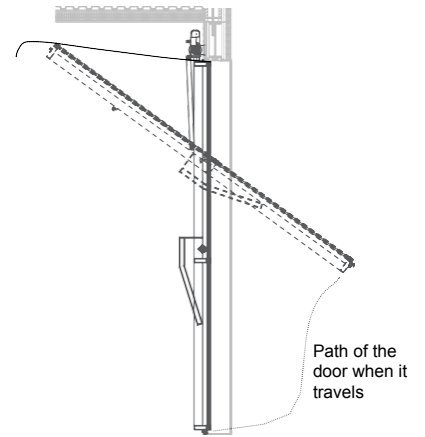
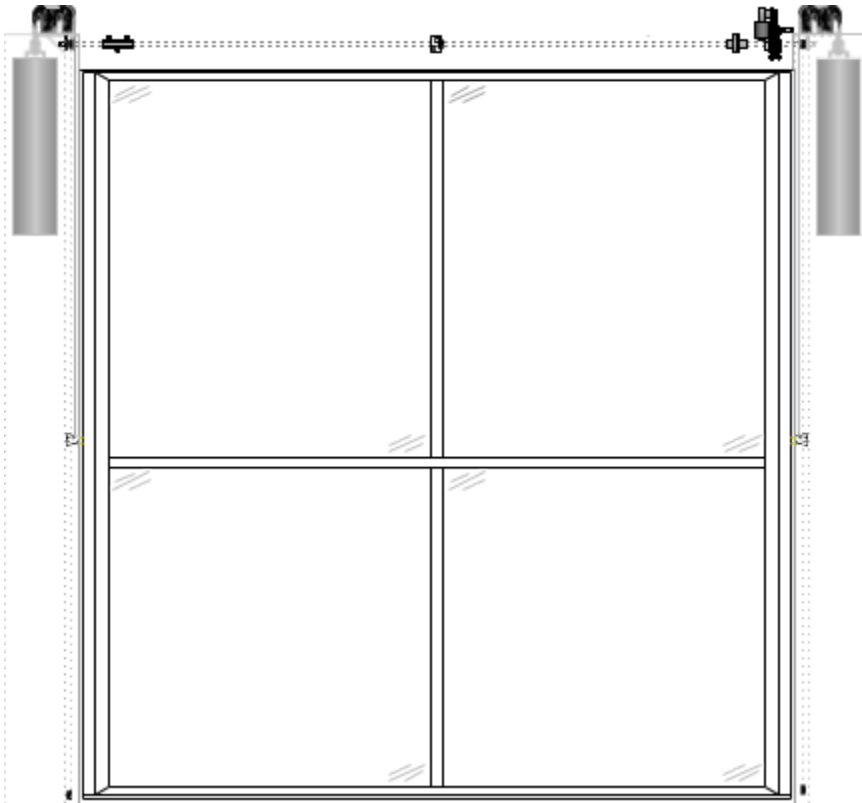

Operating your door

Operating a Motorized Door

Unlock the shoot bolt at the bottom of the door.

The installer will give you a remote control or mount a control unit on your wall. Consult the user manual for your motor to understand how to use your control device.

To operate your door manually, you need to disconnect the door from the trolley by disconnecting the door's cam pin from the sleeve on the trolley. (See the illustration to the right.) The next section explains how to manually open your door.

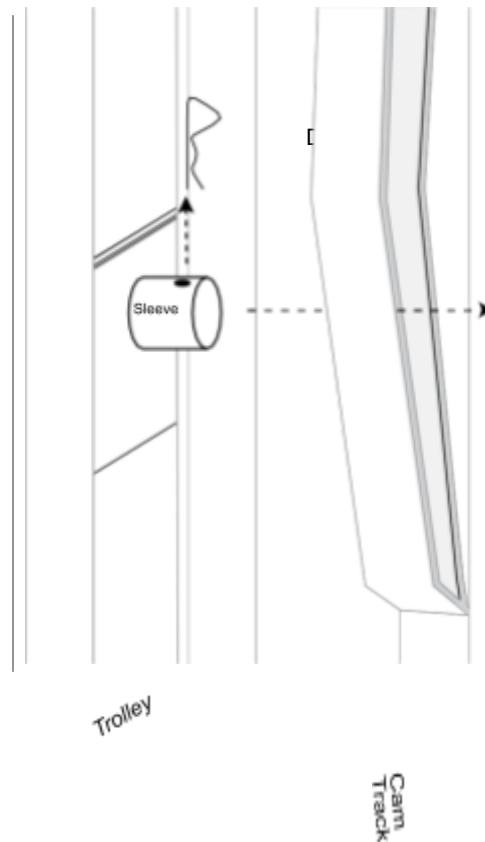

Operating a Manual Door

Unlock the shoot bolt at the bottom of the door.

Open your door manually by pushing the bottom toward the outside and slowly guiding it upward until it gently rests in its open position. (See the illustration on the bottom right.) Be careful not to allow the door to slam open or shut because that will eventually cause damage to the door, possibly making it dangerous to use.

Close the door by gently pulling the bottom down until the door closes fully.

Safety Features for Motorized Doors:

Photo Beam- The installer will place sensors that project a photo beam across the inside of the doorway six inches from the ground. These sensors communicate with the motor while the door is closing so that if anything breaks the beam, the motor will automatically return the door to fully open.

Obstruction Sensing- Each motor will memorize the amount of force necessary to close the door so that it can read interference with the door's movement and return the door to fully open if the door encounters something while it's closing.

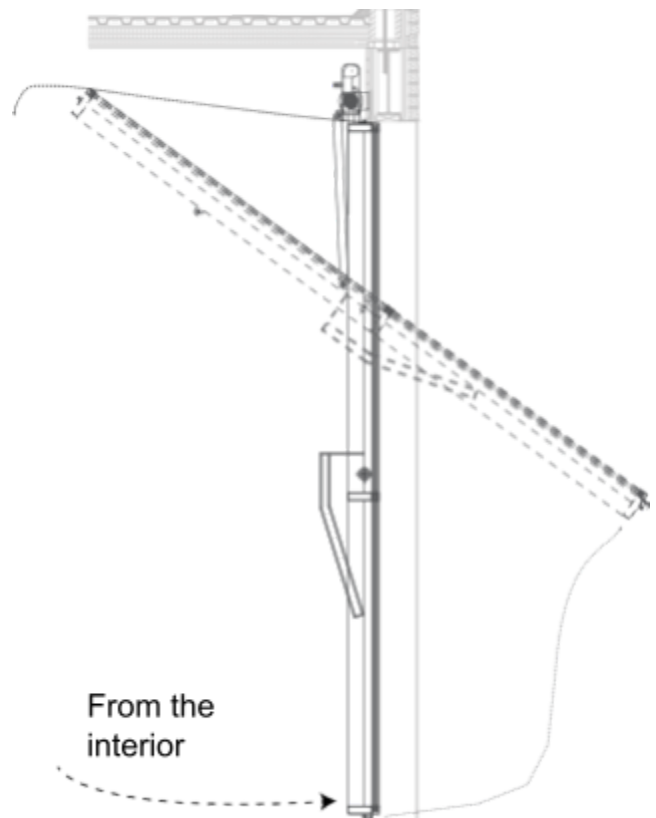

Caring for your door

Regular Cleaning

Follow these steps to clean the powder coating on your door's steel members. If your door has cladding on either side, consult the manufacturer of the cladding to know how best to clean it.

1. Remove residues with a wet sponge.
2. Use a soft brush or a cloth and a mild household cleaner to clean the steel members of your door.
3. Rinse the door with clean water.

What not to do

Do not use cleaners that require you to wear gloves because they could damage the powder coating; the damage may not appear for up to twelve months.

Do not use nylon or steel wool scourers on the powder coating.

When you need a replacement

Contact Renlita Doors if you need a replacement part on your door or if your door becomes difficult to operate.

Never try to fix the door yourself. Visit www.renlitausa.com to find an authorized service technician in your area.

Yearly Check Up

Joint Lubrication:

Lubricate the areas noted in the diagram with a graphite-based lubricant every twelve months.

Cable Inspection:

Inspect the cables every twelve months for frays or other damage by removing the counterweight covers and watching the cables while the door moves. Do not put your hand next to a cable while the door is moving. The dotted rectangles in the drawing show where the covers should be. Contact Renlita Doors immediately if you find any damage on a cable.

Touch-up for the finish:

We provide a can of paint with the door in case at some time you need to refinish a spot on your door. To apply the paint, shake the can well, hold the nozzle 8 – 12 inches from the surface, and apply the paint in light coats to the blemished spot.

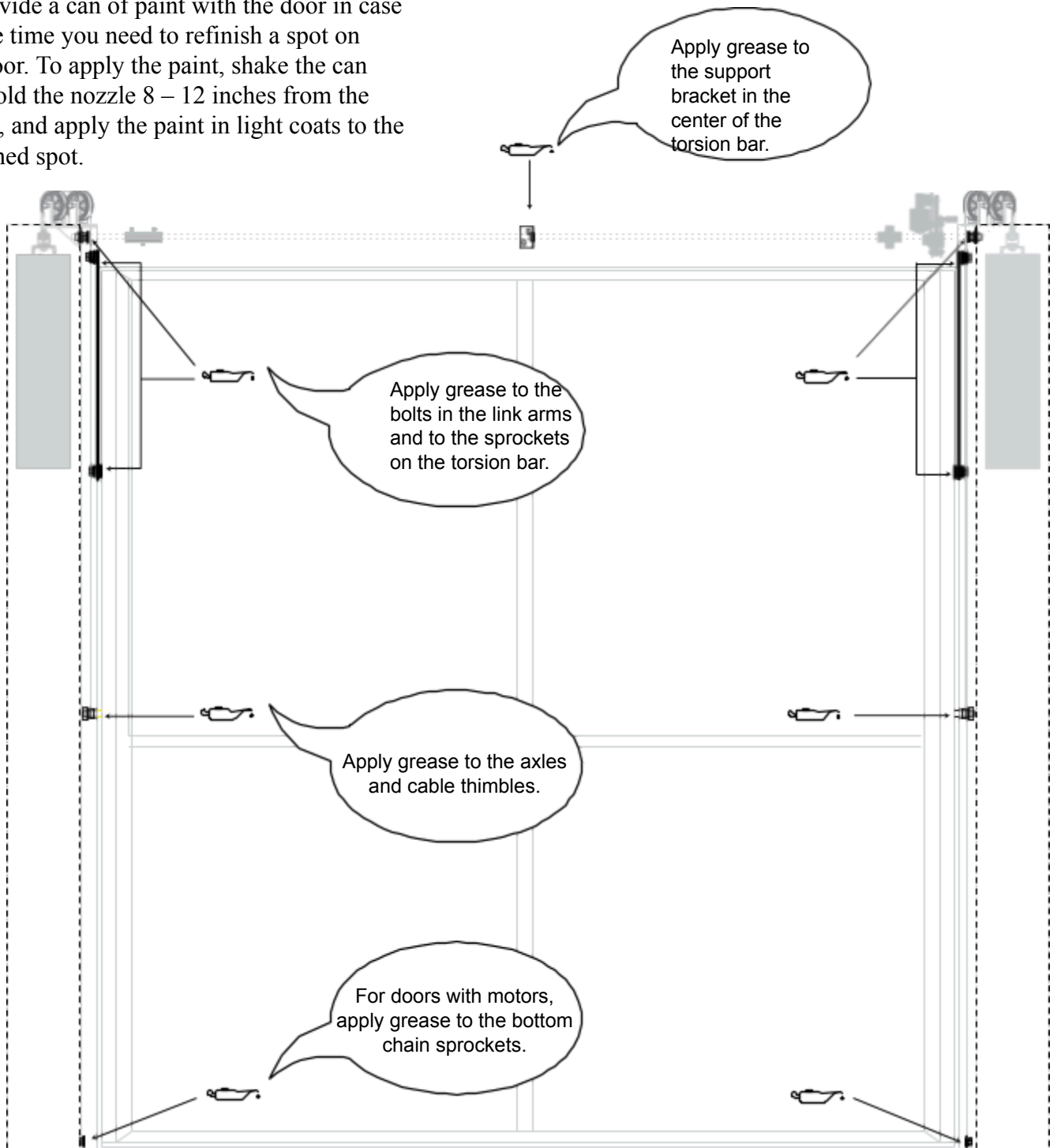

Warranty Information

Limited Warranty

RENLITA DOORS NORTH AMERICA, LLC (Renlita Overhead Doors) warrants to the original purchaser within one year from date of installation, if a product sold under this warranty proves to be defective in material or workmanship through normal use and service according to maintenance and operations instructions, as verified by inspection by persons authorized by Renlita Overhead Doors, Renlita Overhead Doors will replace or repair (at Renlita Overhead Doors option) the defective product.

In addition to general warranty, Renlita Overhead Doors warrants the steel frame against rust, in painted non-damaged condition for a period of one year from original purchase. This warranty does not apply to scratched, dented, damaged or corroded areas of the frame.

Warranties do not cover damage due to: accident, casualty, vandalism, abuse, harmful fumes or foreign substance in the atmosphere, acts of God, fire, failure to provide reasonable control, nor shall these warranties extend to or cover any damages or claims with respect to any product that in any way or degree have been altered, processed, misused, or improperly handled or installed.

Renlita Overhead Doors makes no other warranties, representations or covenants, expressed or implied with respect to this product, as to any matter whatsoever, including but not limited to warranties, representations or covenants as to workmanship, design, capacity, quality, condition, merchantability or fitness for any purpose of the product. Renlita Overhead Doors shall not be responsible for any incident or consequential damages arising out of the breach of this limited warranty, including but not limited to damage to buildings, other property, or other injuries or damages sustained by any persons whomsoever, or the recovery of any direct or indirect costs such as shipping, installation labor charges, paint or painting, or other building materials.

These warranties give you specific legal rights and you may also have other rights, which vary from state to state. All claims under these warranties shall require proof of purchase and be addressed to Renlita Doors North America, LLC P.O. Box B, Bonham, TX 75418

Contact us

Sales
903-583-7500
sales@renlitadoors.com

Technical Support
903-486-3301
support@renlitadoors.com

Renlita Doors North America, LLC
P.O. Box B
Bonham, TX 75418

Visit our website at www.renlitausa.com
to see other innovative products from
Renlita Doors.