



# **Installation Manual**

E-Series Linear Actuator Systems  
Including Wave and Vue Models

## Congratulations on your purchase of your new Renlita E-Series Door!

We have engineered your door specifically for your project's design and we are confident that your system will provide you with many years of enjoyment and space flexibility. We pride ourselves in great service and robust, sleek custom openings so please let us know how we're doing!

### We're here to help:

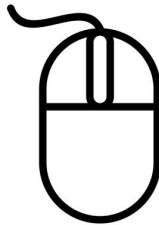

**EMAIL SUPPORT**  
Support@Renlitadoors.com



**PHONE SUPPORT**  
(903) 486-3301



**INSTALLATION INSTRUCTIONAL VIDEO**

# TABLE OF CONTENTS

## Table of Contents

What You Should Know Before You Begin	4
Parts Included With Your Door	4
Typical Vue Configuration	5
Typical Wave Configuration	6
Process 1 - Gathering Tools & Materials	7
Process 2 - Examining the Installation Area	7
Process 3 - Set Up a Work Zone	8
Process 4 - Prepare the Pieces	9
Face-Mounted Systems (With Welded-In Axles)	9
Process 5a - Position the Door	9
Process 6a - Assembling the Side Rails to the Door Frame	10
Process 7a - Fastening the Door to Jamb Structure	11
Inside-The-Jamb Mounted Systems	12
Process 5b - Position the Door	12
Process 6b - Assembling the Side Rails to the Door Frame	13
Process 7b - Fastening the Door to Jamb Structure	14
Process 8 - Glass Installation	15
Process 9 - Affixing the Glazing Caps	16
Process 10 - Installing the Linear Actuators, Wire Tray, & Photo Eyes	17
Process 11 - Control Box Connections	18
Process 12 - Setting the Door's Up & Down Limits	19
Process 13 - Installing the Top & Bottom Seals	20
Process 14 - Installing the Threshold	21
Operating Your EVO-Door	22

## What You Should Know Before You Begin

Make sure you obtain and follow the shop drawings in each shipment because they alone specify each door's particular configuration. Do not begin an installation without them.

Never substitute hardware or components. You must always use the hardware and components that are provided with your door. If any replacement parts are needed please contact Support at (903) 486-3301.

Use the appropriate tools, equipment, and personal protective gear to install the door so that you ensure a safe and quality installation.

## Parts Included With Your Door

<b>A</b>	DOOR FRAME ASSEMBLY	1	<b>Q</b>	LINEAR ACTUATOR	2
<b>B</b>	OPERATING CHANNEL ASSEMBLY	2	<b>R</b>	CONTROL PANEL	1
<b>C</b>	TRACK TOP ANGLE ASSEMBLY	1	<b>S</b>	TOUCH SCREEN CAT5 KIT	1
<b>D</b>	GLAZING CAPS	1	<b>T</b>	FLOOR MOUNT PHOTO EYES	1
<b>E</b>	TOP SEAL RETAINER	1	<b>U</b>	2 CONDUCTOR WIRE (22 AWG)	50
<b>F</b>	E-SERIES CABLE TRAY	1	<b>V</b>	WIRE NUTS	4
<b>G</b>	E-SERIES HARDWARE KIT	1	<b>W</b>	4" THERMAL BREAK THRESHOLD	1
<b>H</b>	SANTOPRENE SIDE SEAL	1	<b>X</b>	3/16" X 2-3/4" FLAT HEAD CONCRETE SCREW	25
<b>I</b>	3/4" BLACK FOAM D SEAL (12')	1	<b>Y</b>	3/8" X 1/4" THREAD CUTTING SCREW	30
<b>J</b>	THRESHOLD SEAL	1	<b>Z</b>	AERO LUBRIPLATE GREASE	1
<b>K</b>	GLAZING SEAL (100')	1	<b>AA</b>	DOW CORNING 995 CAULK	1
<b>L</b>	1/4" GLAZING TAPE (50')	2	<b>BB</b>	E-SERIES INSTALLATION KIT	1
<b>M</b>	SETTING BLOCKS (SHIMS) 1/4" X 1/2"	12	<b>CC</b>	GLASS	1
<b>N</b>	GLAZING SCREWS	50	<b>DD</b>	E-SERIES TOUCH UP PAINT	1
<b>O</b>	SILICONE SEALANT	3			

# TYPICAL CONFIGURATION

## Typical Vue Configuration

NOTE: YOUR DOOR SIZE AND LAYOUT MAY VARY. REFER TO YOUR INCLUDED SHOP DRAWINGS FOR THE MOST ACCURATE DEPICTION OF YOUR CUSTOM VUE.

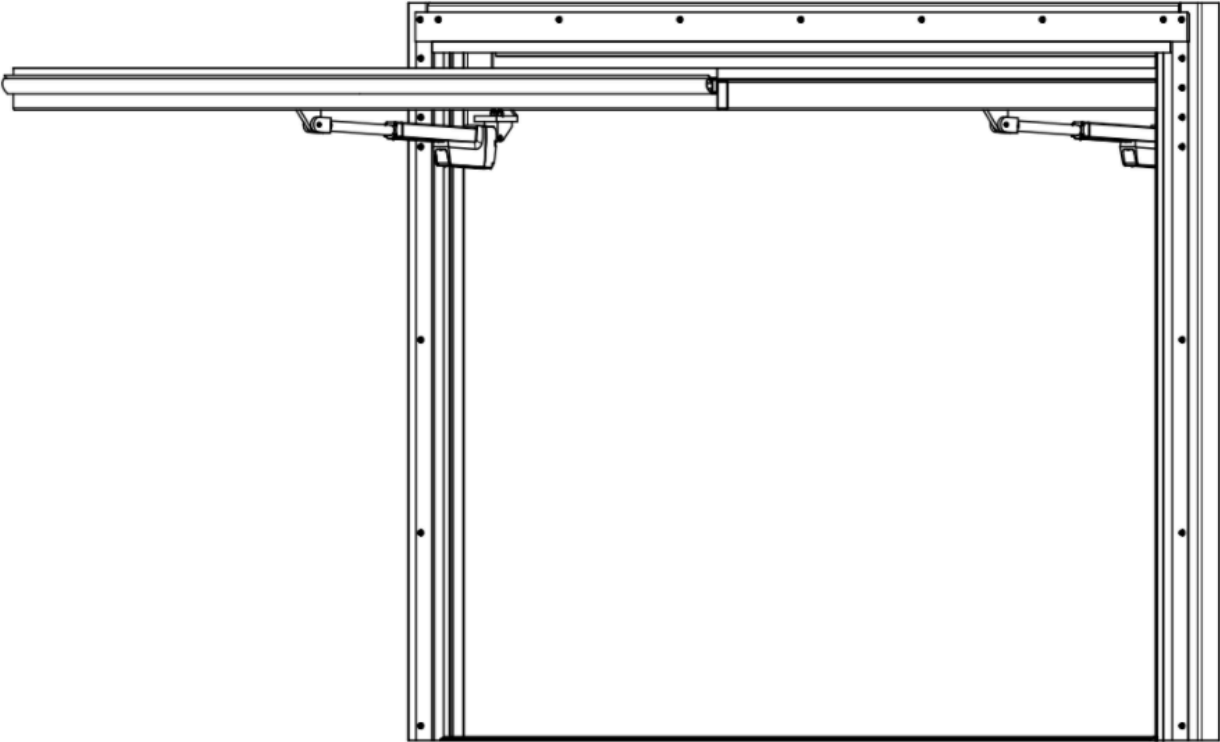
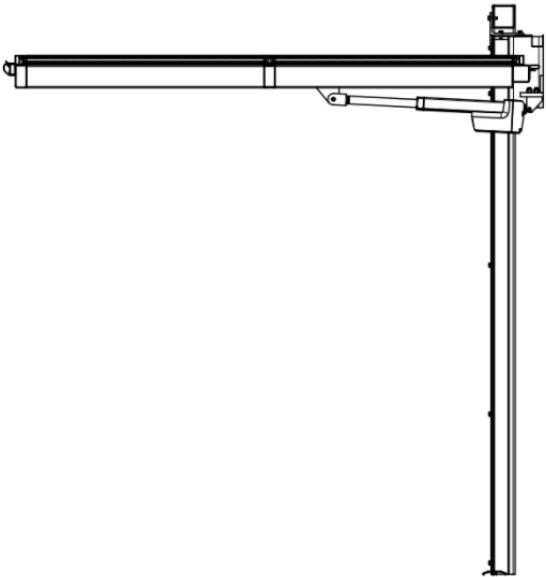
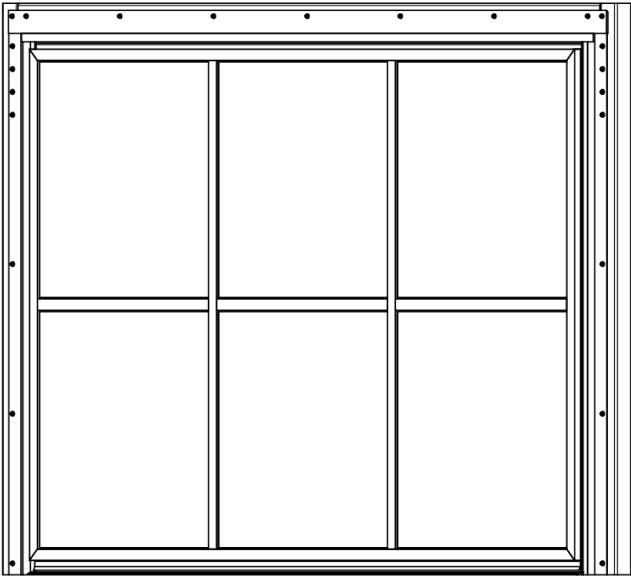

# TYPICAL CONFIGURATION

## Typical Wave Configuration

NOTE: YOUR DOOR SIZE AND LAYOUT MAY VARY. REFER TO YOUR INCLUDED SHOP DRAWINGS FOR THE MOST ACCURATE DEPICTION OF YOUR CUSTOM WAVE.

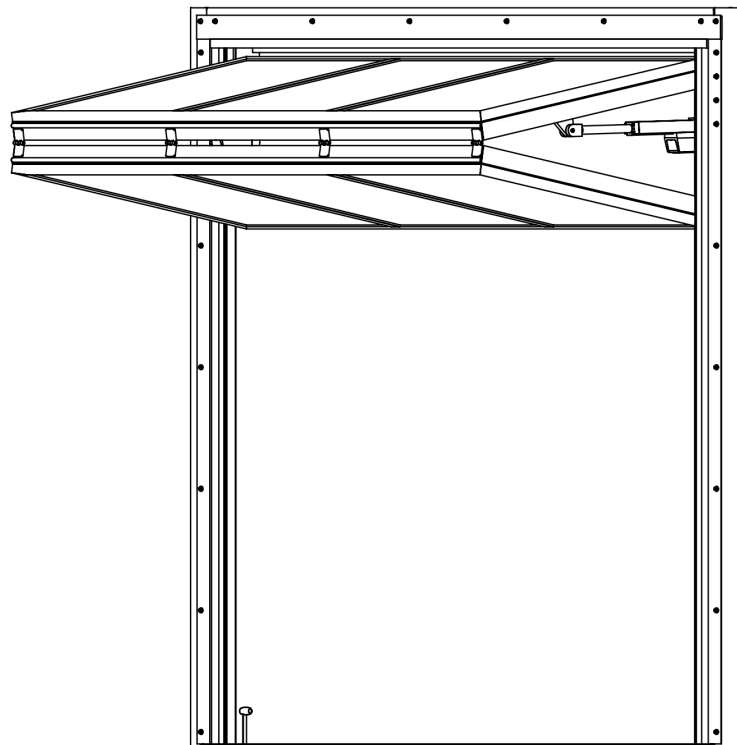
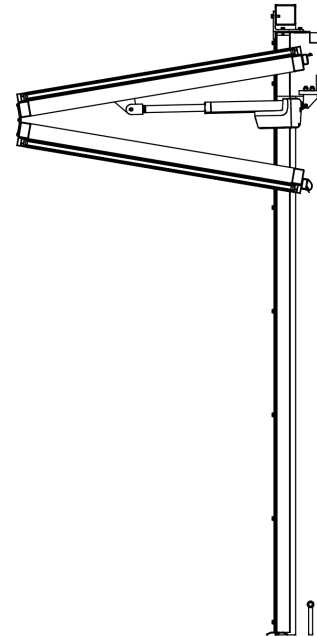
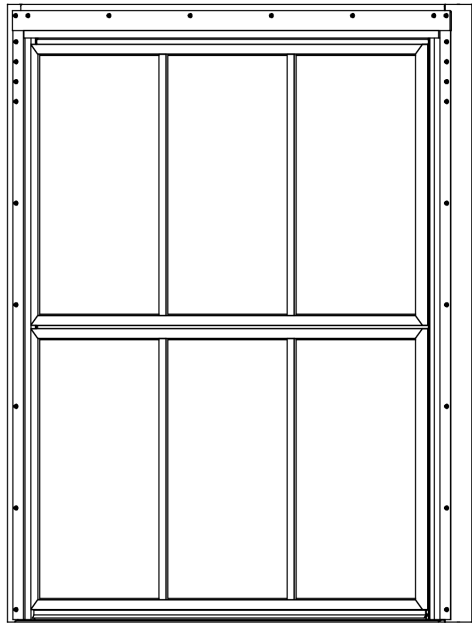

## Process 1 - Gathering Tools & Materials

What tools and materials will you need to provide and what is included in your installation kit?

- A. Tape Measure
- B. Rubber Mallet
- C. 3 Clamps
- D. Pry Bar
- E. Power Drill
- F. Metal Drill Bits
- G. Socket Set with Drill/Socket Adapter
- H. Phillips and Flat Head Screwdriver Bits
- I. Utility Knife or Shears
- J. Shims
- K. Glazing Suction Cup\*
- L. Slip Ring Pliers\*
- M. Alcohol Wipes\*
- N. Zip Ties\*
- O. Lubricant\*
- P. Caulk\*

\*Provided with the E-Series door installation kit.

## Process 2 - Examining the Installation Area

Compare the shop drawings to the doorway to ensure the following:

- A. The finished floor height matches the drawings provided with your door
- B. There is ample space for the door to open and close without hitting the floor or the ceiling, or any other structure or furnishing
- C. Appropriate space within the doorway for the door panel
- D. Appropriate space at the jambs and at the header for the operating channels
- E. The doorjamb material (steel, concrete, wood etc.) is the same as shown in your drawings

# SET UP A WORK ZONE

## Process 3 - Set Up a Work Zone

- A. Notify other workers in the area that the doorway will be inaccessible from the time you begin the installation until it is complete. No hoses, cords, or other equipment can be allowed in the opening as you will need this entire space for installation.
- B. Set up your safety zone according to the illustration below.

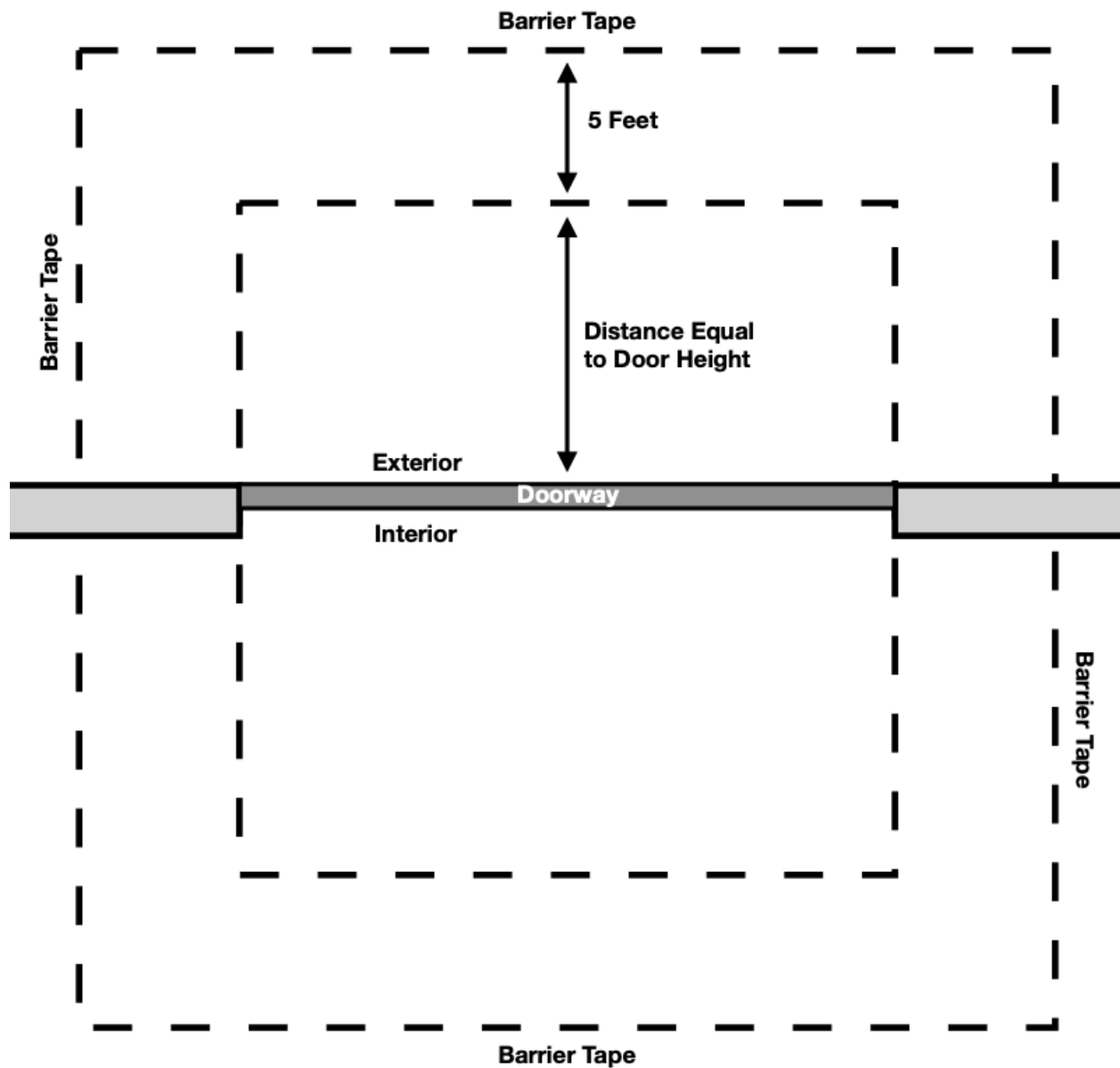

# PREP & POSITION THE DOOR

## Process 4 - Prepare the Pieces

- A. Locate and place the glass panels and glazing caps out of the way to protect them from damage until needed.
- B. Insert the side seals into the side seal retainer.
- C. Position the rails for assembly to the side of the door panel.

## Face-Mounted Systems (With Welded-In Axles)

### Process 5a - Position the Door

**\*NOTE: Steps 5a-7a are for E-Series systems engineered to be fastened to the interior or exterior face of the jambs. For inside-the-jamb systems please skip to page 12 for alternate instructions.**

- A. Set the door on the mounting side of the jambs. This is typically toward the exterior but confirm this with your shop drawings.
- B. Set down soft material so that you will not accidentally scratch or otherwise damage the finish of the door.
- C. Lay the door panel flat on the ground in front of the doorway on the exterior side with the glazing system on the bottom. If the door is mounting to the interior, place the door panel to the interior, with the glazing system up.
- D. Set the door on a soft material so that you will not accidentally scratch or otherwise damage the finish.
- E. Slide the flanged bushing into the jamb at each axle location. Make sure that the axle and flanged bushing are lubricated properly. On Wave doors you'll want to ensure the rollers are placed within the jamb tracks appropriately as well.
- F. Position the header angle at the top of the door above the side rails.

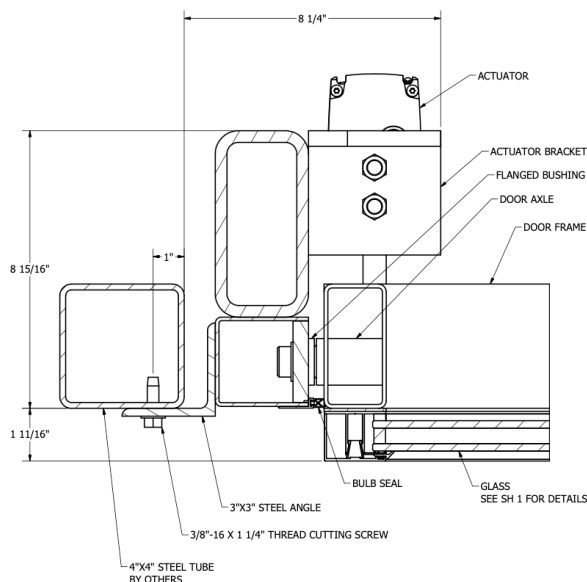

01 JAMB DETAIL

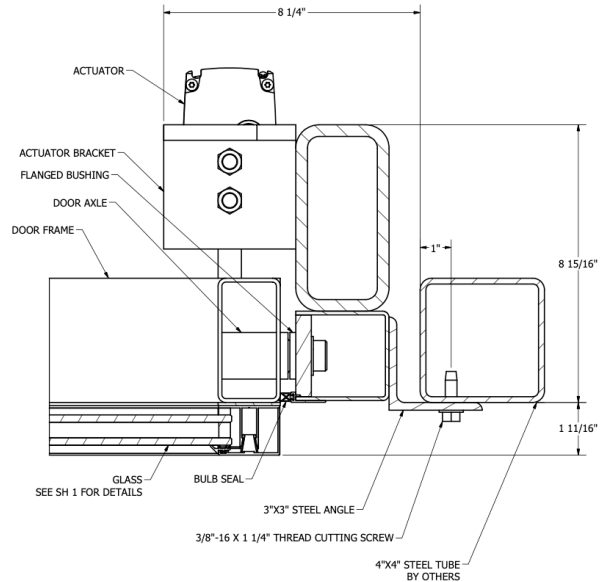

02 JAMB DETAIL

# ASSEMBLING THE SIDE RAILS

## Process 6a - Assembling the Side Rails to the Door Frame

- A. With the door laying down and the flange bushing in each jamb slide the side rails on so that the bushing in the side rail receives the axle.
- B. The flange side of the bushing will be in between the door and the side rail.
- C. Using shims, adjust the height and align the side rails and header angle with the door frame.
- D. Clamp the side rails and header angle to the frame, taking care to keep everything square.
- E. The header angle will then bolt to the top of each side rail with two bolts in each side.
- F. Make sure the rails are oriented correctly per your drawings before attaching the header angle.

Header Angle

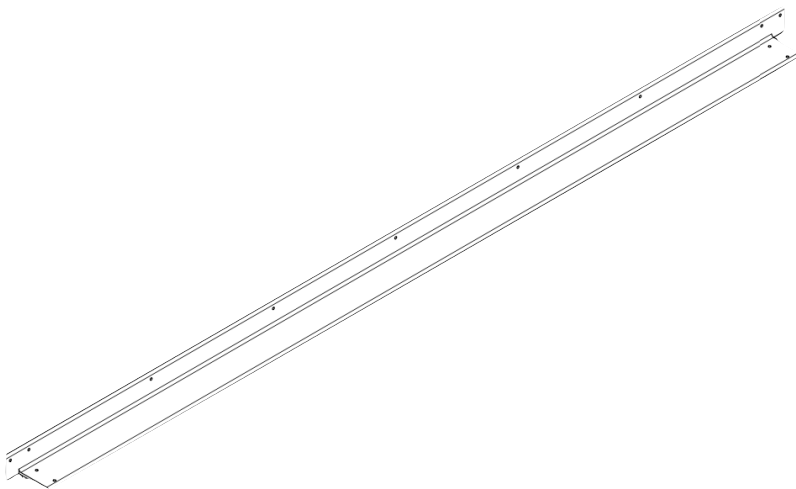

Side Rails

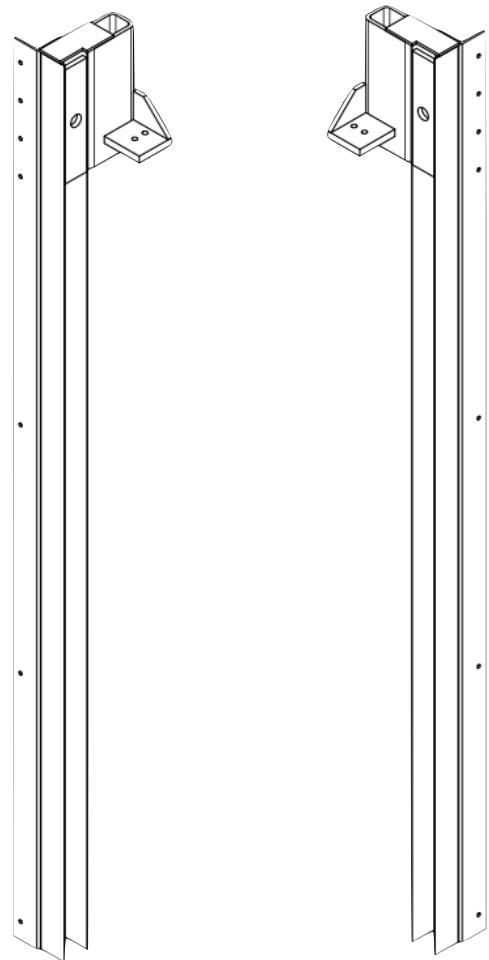

# FASTENING TO THE JAMB

## Process 7a - Fastening the Door to Jamb Structure

- A. Before standing the door into the opening, secure the bottom of the door frame on both sides using the jamb pins, and lock them into place using the provided T-pins, if available, or simply clamp the frame in place.
- B. Stand the door up into the opening with a lift, or at least one person on each side of the door by lifting the door from the top and pushing upwards to stand it up into the opening. If using a lift, always secure the door to the lift using a clamp.
- C. Place shims under the door to provide enough space for the bulb seal, thresholds, and finish flooring. If finish flooring is not yet installed, ensure that you leave enough space for it so that the door is able to close once the flooring is completed.
- D. Using a laser level, level the door inside the opening. Remember the door must be completely level before securing the side rails to the jamb. If the door needs to be level, you **MUST** go UP NEVER down with the door.
- E. Drill a hole into the jamb using the provided drill bit in one of the existing holes on the left and right of the header angle, and secure the door using the provided fasteners. Welding the header and side jambs is also acceptable, though less adjustable.
- F. Once your door is secured at the top, and using the side seal as a guide, place each jamb where the seal is just touching the frame member, taking care not to smash or overly compress the seal.
- G. Continuing from the top to the bottom fastening the rails using the provided fasteners in each pre-drilled hole.
- H. It is important to use a fastener in each provided hole in the frame, and to make sure each fastener is tightened appropriately. Skip to Process 8 Glass Installation on page 15 to continue.

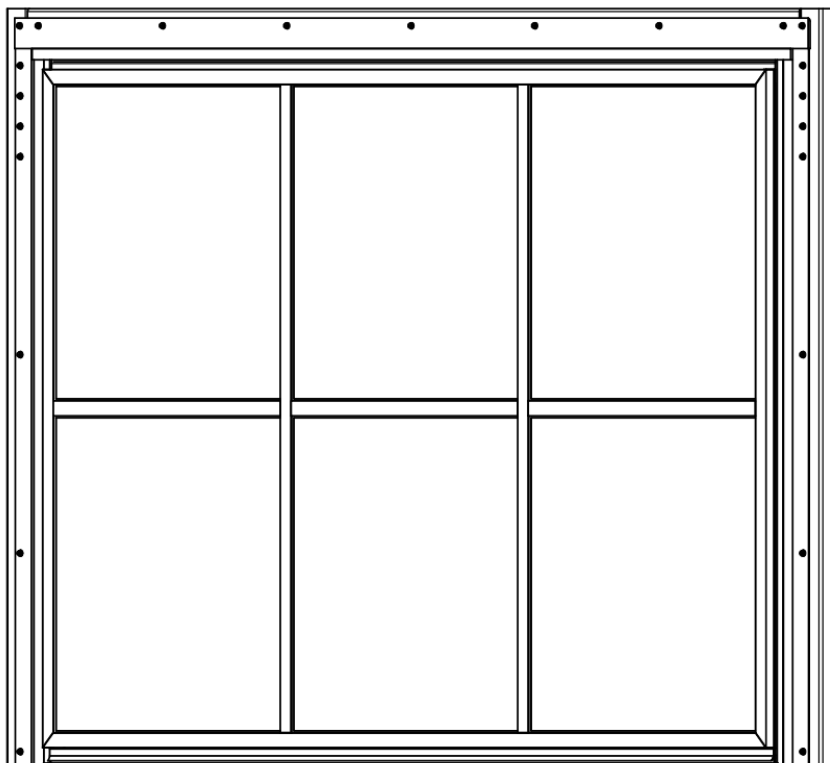

Start fasteners at the top and work downward.



# POSITION THE DOOR

## Inside-The-Jamb Mounted Systems Process 5b - Position the Door

**\*NOTE:** Steps 5b-7b are for E-Series systems engineered to be fastened to the inside face of the jambs. For face-mounted systems please go back to page 9 for alternate instructions.

- Set the door on a soft material so that you will not accidentally scratch or otherwise damage the finish.
- Set the door on its exterior face (glazing system down) and position the left and right door jambs (rails) on the appropriate sides of the door panel.
- Slide the flanged bushing into the jamb at each axle location. On Wave doors you'll want to ensure the rollers are placed within the jamb tracks appropriately as well.
- Refer to your drawings for the correct spacing off the FINISHED floor. If there is no finish flooring at the time of installation, you will need to take the finish floor thickness into account while setting door.
- Set the door on the mounting side of the jambs, center the header plate and rails in the opening. This is typically toward the exterior but confirm this with your shop drawings.

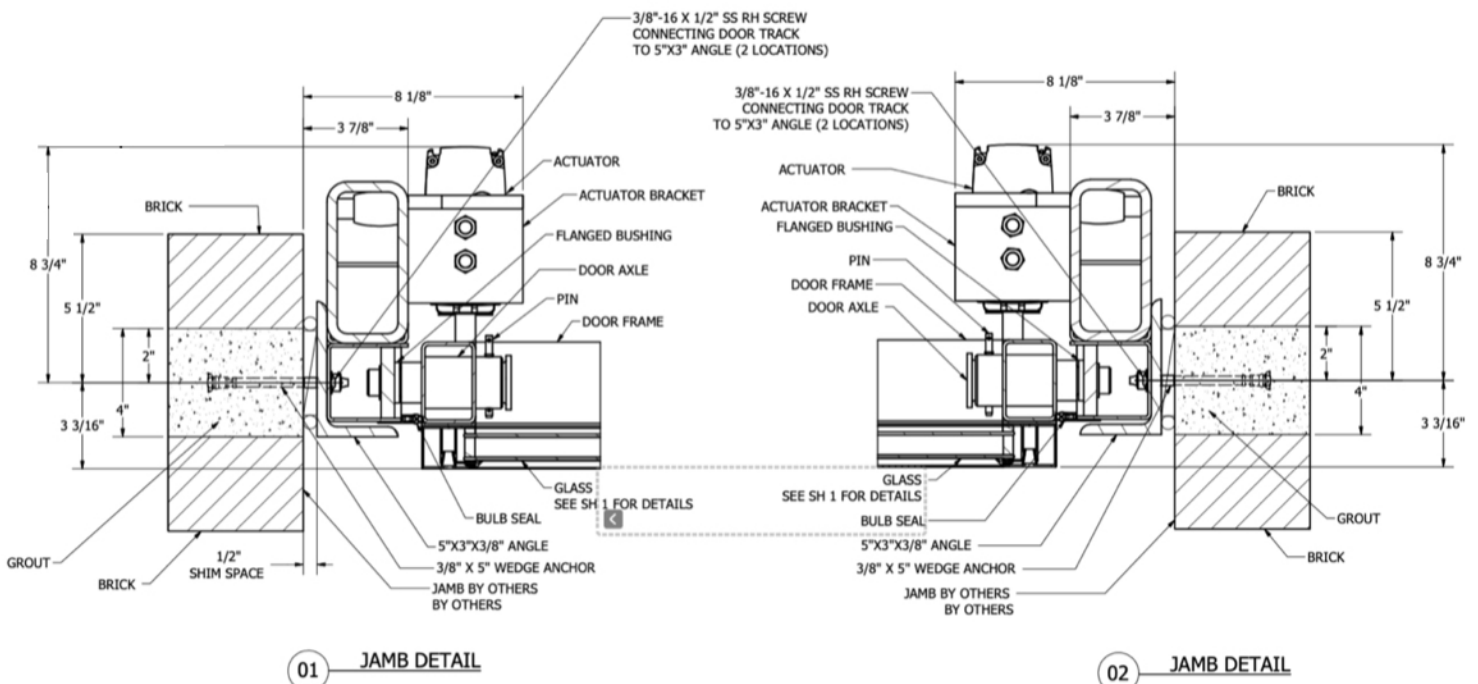

# ASSEMBLING THE SIDE RAILS

## Process 6b - Assembling the Side Rails to the Door Frame

- A. With the door laying down and the flange bushing in each jamb slide the side rails on so that the bushing in the side rail receives the axle. Make sure the axle and flanged bushing are lubricated properly.
- B. Pin the door by sliding the door lugs into the bushing on the rails to get the seal gap right. Ensure that the side seal are making contact with the door, but not compressed too tightly.
- C. Attach the header plate and side rails by using provided hardware and predrilled holes on header. Though the header plate has predrilled holes, you will need to drill pilot holes into the plate at the top of the rails at the appropriate position.

Header Angle

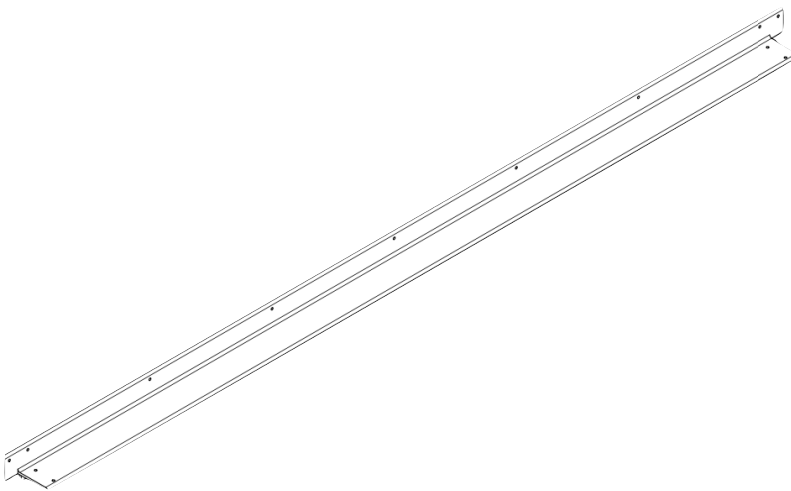

Side Rails

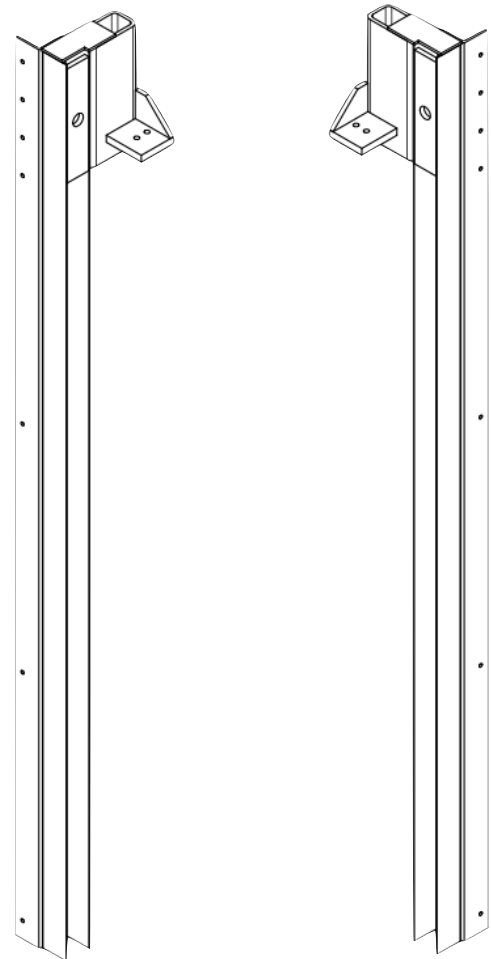

# FASTENING TO THE JAMB

## Process 7b - Fastening the Door to Jamb Structure

- A. Before standing the door into the opening, secure the bottom of the door frame on both sides using the jamb pins, and lock them into place using the provided T-pins, if available, or simply clamp the frame in place.
- B. Stand the door up into the opening with a lift, or at least one person on each side of the door by lifting the door from the top and pushing upwards to stand it up into the opening. If using a lift, always secure the door to the lift using a clamp.
- C. Place shims under the door to provide enough space for the bulb seal, thresholds, and finish floor, if needed.
- D. Using a laser level, level the door inside the opening. Remember the door must be completely level before securing the side rails to the jamb.
- E. Once the door is level, and centered, measure the bottom of the rails to the actual floor, then take the whole door system out, unpin the panel, then raise the rails and header back into the open shimming the rails, secure the header plate with the provided hardware.
- F. Put your door panel back in place, shim the rails to where the side seal just touches the panel.
- G. Once your door frame is secured at the top, and using the side seal as a guide, take the panel out, start securing the rails to the jambs with provided hardware.
- H. It is important to use a fastener in each provided hole in the frame, and to make sure each fastener is tightened appropriately.
- I. Finally, placing the panel back in frame, ensuring the side seals are touching the door panel, adj. as needed by adding shims.

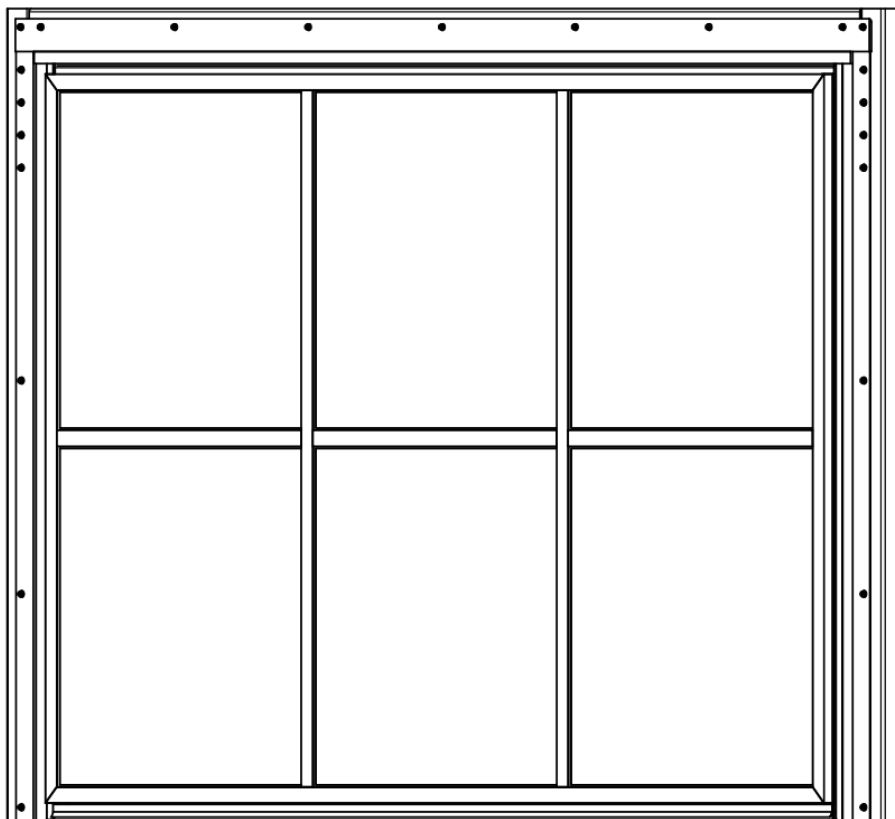

Start fasteners at the top and work downward.



# GLASS INSTALLATION

## Process 8 - Glass Installation

**NOTE: GLASS MUST BE INSTALLED IN TEMPERATURES ABOVE 30° FAHRENHEIT AND IN A DRY ENVIRONMENT.**

- A. Use the provided wipes to clean the base of the glass capture system indicated in the illustration in red, blue, and green. This is where you will place your glazing tape, so ensure that there is no dust, dirt, or oil on the interior base of the caps.
- B. Carefully place the glazing tape flush to the inside of each aluminum piece per the illustration. Begin by placing tape along the perimeter captures as shown in red followed by the interior horizontal mullions indicated in blue and finally the vertical mullions indicated in green.
- C. Once the tape has been secured in the proper location you may remove and discard the blue plastic adhesive cover.
- D. Apply the provided caulk at each corner or any place where the glazing tape is cut, being careful not to use too much.
- E. Install two of the black rubber shims provided in each section. These should be placed roughly 6 inches from the bottom right and bottom left corner of each section. This will position the glass properly when placing the units in subsequent steps.
- F. Remove any film and ensure each piece of glass is clean before using the suction cups to lift the glass into place. Refer to page one of your drawings to make sure that you orient the piece of glass with the correct side to the exterior.
- G. Gently set the glass on the rubber shims and center the glass within the glazing system.
- H. Apply gentle pressure around the perimeter of the glass to adhere it to the glazing tape.
- I. You may also use the small caps from the glazing bundle to hold the glass while you affix the remaining pieces in each section, and remove the shims under the door using a pry bar.

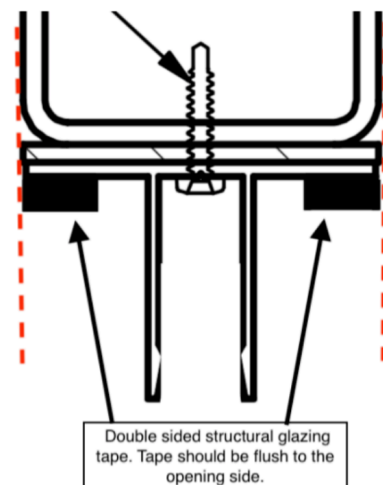
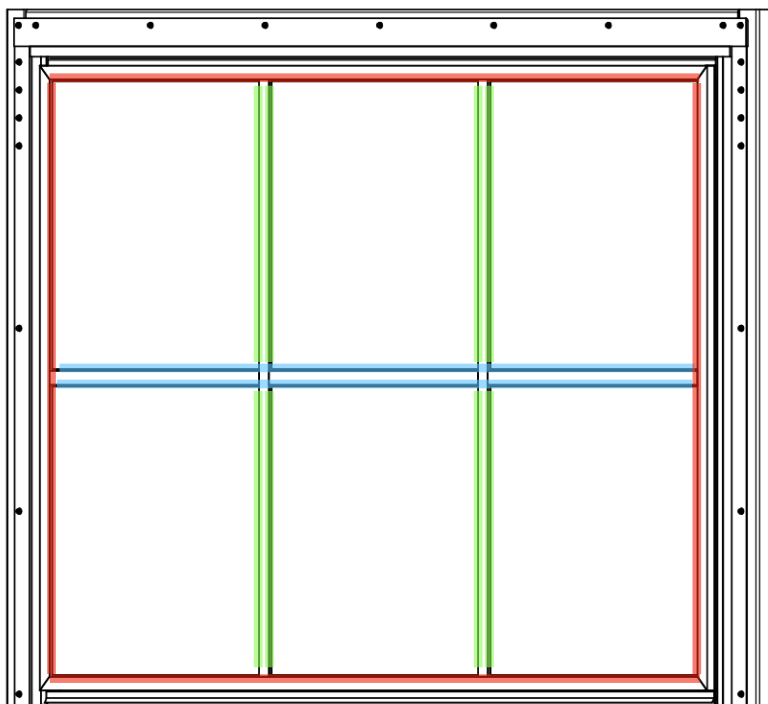

# GLAZING CAP INSTALLATION

## Process 9 - Affixing the Glazing Caps

**NOTE: IN THE STEP YOU WILL BE TRIMMING THE SEALS BUT DO NOT TRIM THE GLAZING CAPS BECAUSE THEY HAVE BEEN FITTED PROPERLY IN THE FACTORY. THE GLAZING CAPS WILL BE LABELED TO INDICATE THEIR PLACE ON THE DOOR.**

- First, locate the four perimeter glazing caps. These caps will be mitered at 45° on both ends.
- With the glazing seals in place trim the cap seals so that they will not push up the seals of any caps they intersect with later, shown in Figure A.
- Next trim the perimeter glazing seals at the intersection points of the vertical and horizontal caps, circled in Figure B. These seals should be cut perpendicular to the glazing cap in which they are attached, not at an angle. You will also need to cut a similar gap in the seals of the long horizontal caps where the long vertical caps will intersect them.
- Next trim the seals flush with the ends of the horizontal and vertical caps, being careful to not trim them too short.
- Once all seals have been properly trimmed you may begin installing the glass capture caps by aligning their interior connection channels and gently but firmly tapping them into place with a rubber mallet.

**Tip: Place the perimeter caps first, followed by the horizontal caps, and finish with the smallest, vertical caps.**

Figure A

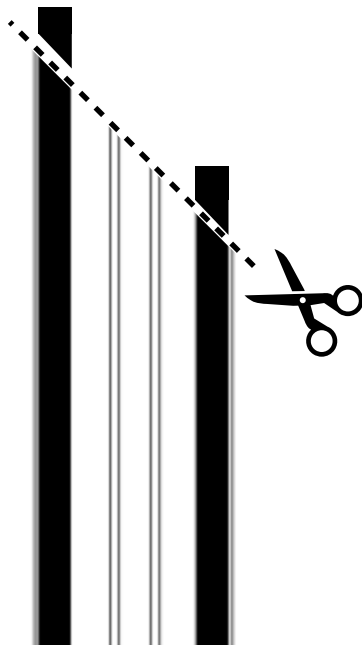
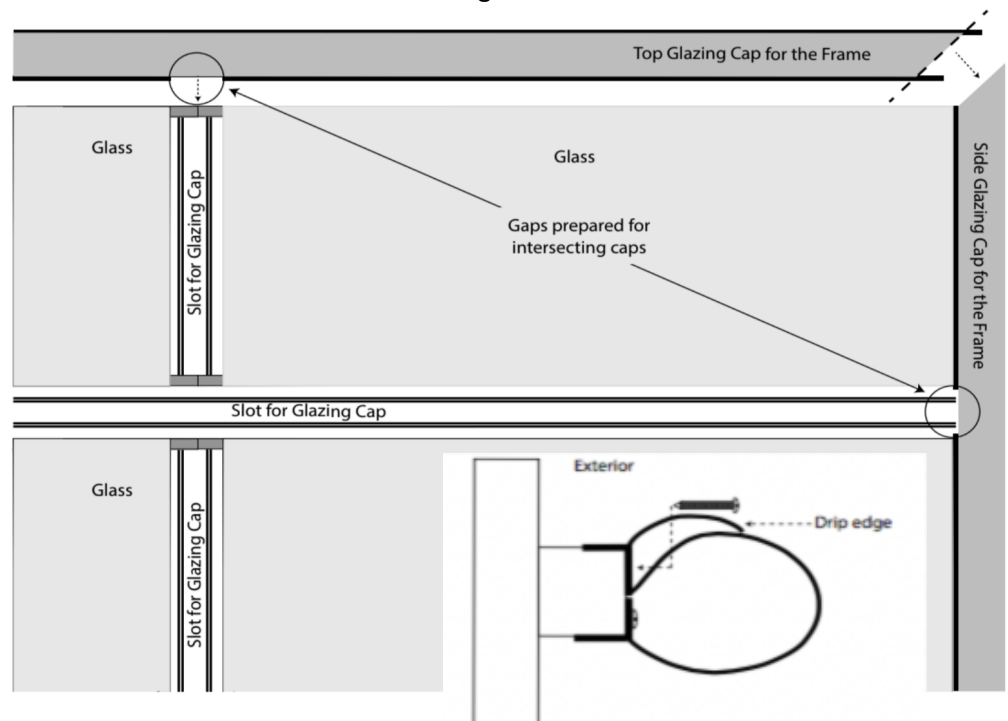

Figure B



# INSTALLING LINEAR ACTUATORS

## Process 10 - Installing the Linear Actuators, Wire Tray, & Photo Eyes

**NOTE: THE ACTUATORS SHOULD BE FULLY EXTENDED AND THEN FULLY RETRACTED BEFORE ATTACHING THE ACTUATOR PUSH ROD TO THE DOOR FRAME. THIS CAN BE DONE BY CONNECTING THEM TO THE CONTROL BOARD AND PRESSING THE JOG UP BUTTON UNTIL THEY STOP, THEN PRESSING THE JOG DOWN BUTTON UNTIL THEY STOP.**

- A. Mount the motor brackets to the door side rails using the provided bolts.
- B. Next, mount the linear actuators with the large motor at the top as shown in the illustration. Attach the actuators to the motor brackets using the half inch pins provided, and secure them using the provided snap rings as shown.
- C. Install the wire tray to the top angle using the provided self tapping fasteners. It should be oriented with the channel facing up so that the wiring may lay flat within the channel, out of sight.
- D. Mount the photo eye receiver and transmitter using the supplied brackets or, if your design allows, you may flush mount these into the adjacent walls or jambs by drilling a hole on the right and left sides of each door and sliding the receiver and transmitter into place with the threaded retainer ring removed. You may then tighten the retainer ring to secure the photo eyes, taking care that they align with each other.
- E. The photo eyes should be to the interior of the door, and must be placed 3 to 6 inches above the finished floor.
- F. Route all cabling to the control box location and place the cables into the cable tray to hide them. The cables can also be pushed into the linear actuator's cable management channels.

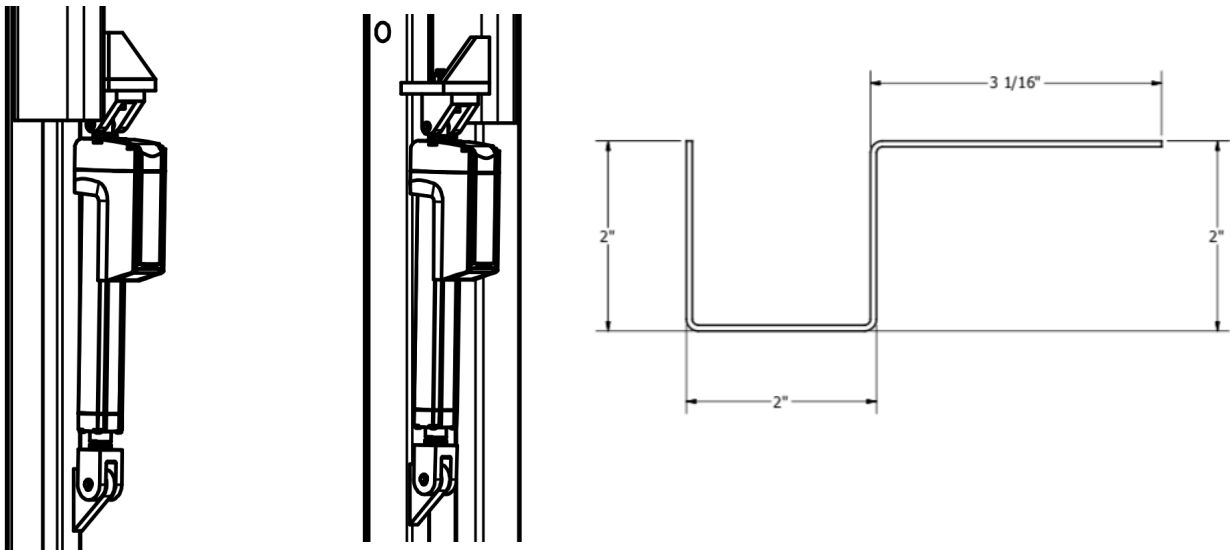

# CONTROL BOX CONNECTIONS

## Process 11 - Control Box Connections

**NOTE: EACH DOOR WILL HAVE TWO LINEAR ACTUATORS. THE MASTER ACTUATOR WILL PROVIDE INSTRUCTIONS TO THE SLAVE ACTUATOR ON SPEED AND TIMING TO ENSURE THAT BOTH ACTUATORS REMAIN SYNCHRONIZED DURING OPERATION.**

- A. Connect your touchscreen using the provided network cable by inserting it into one of the RJ45 ports on the control board labeled Display Coms. The other end of the cable will be inserted into the rear of the touch panel at the touch panel location.
- B. Each actuator will have two cables. Connect the Master actuator's control connector to the board using the port labeled Master Actuator. Then connect the master actuator's power cables to the screw terminals. The red cable should be connected to the screw terminal labeled Master Positive and the black cable to the terminal labeled Master Negative. Repeat the connection process for both cables for the slave actuator.
- C. The photo eyes will have a two wire cable attached to the transmitter and the receiver. To connect these wires to the motor controller board you will need to strip and trim each wire with one quarter inch of insulation removed. Twist both black wires together, and both red wires together, then trim the two pairs down to the appropriate length to ensure that the conductors do not touch when connected to the control board's terminals. Insert each twisted and trimmed pair into either the positive or negative terminal on the Photo Sensor connector. Properly align the photo eyes so that the receiver and transmitter show a green and red light. If not properly aligned both lights will show red.

**Tip: Polarity does not matter with the photo eye cables, meaning there is no positive or negative wire.**

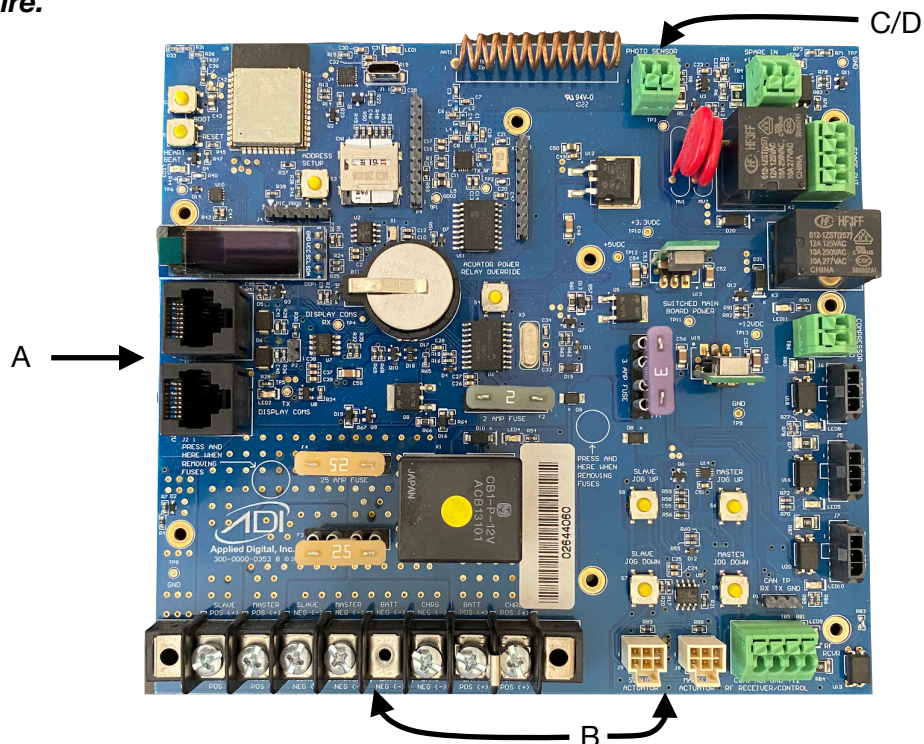

## Process 12 - Setting the Door's Up & Down Limits

- A. Test your control panel connections by pressing the Jog Up button briefly to make sure that the door panel moves upward. Make sure to remove any clamps or locking pins first.
- B. If the door is moving as it should, press and hold the Jog Up button until the door reaches the fully open position. Then, reverse the door using the Jog Down button to your desired open position.
- C. To set the open limit, press and hold BOTH (master and slave) Jog up button's until the door reaches the desired open position. Once in the open position, check to make sure the door panel is level, then touch the bottom right hand corner of the touch screen while on the Home screen, and another screen will pop suppress "Learn open." Repeat the process for the close position, by pressing BOTH jog down buttons, then "Learn Close" You will be asked a series of questions to configure your door. Answer these questions as prompted for your particular installation.
- D. You may now test the door opening sequence by pressing the Open button on the touch panel. The door will travel to the fully extended position first, If adjustments are needed to the limit's position, jog the door to where you want it, then press the learn open/close button.
- E. Test the door closing position by pressing and holding the Down button until the door reaches the fully closed position. Note: Lowering the door requires that the Down button be held until the door is fully closed.
- F. Once the limits have been set and the correct motion confirmed through the touch panel it is important to test the safety photo eyes to ensure their proper operation. To do this simply open the door first and once fully opened, press and hold the down button. While the door is in operation downward, have someone block the transmitter or receiver photo eye. This should stop the door panel which should then return to the fully open position.

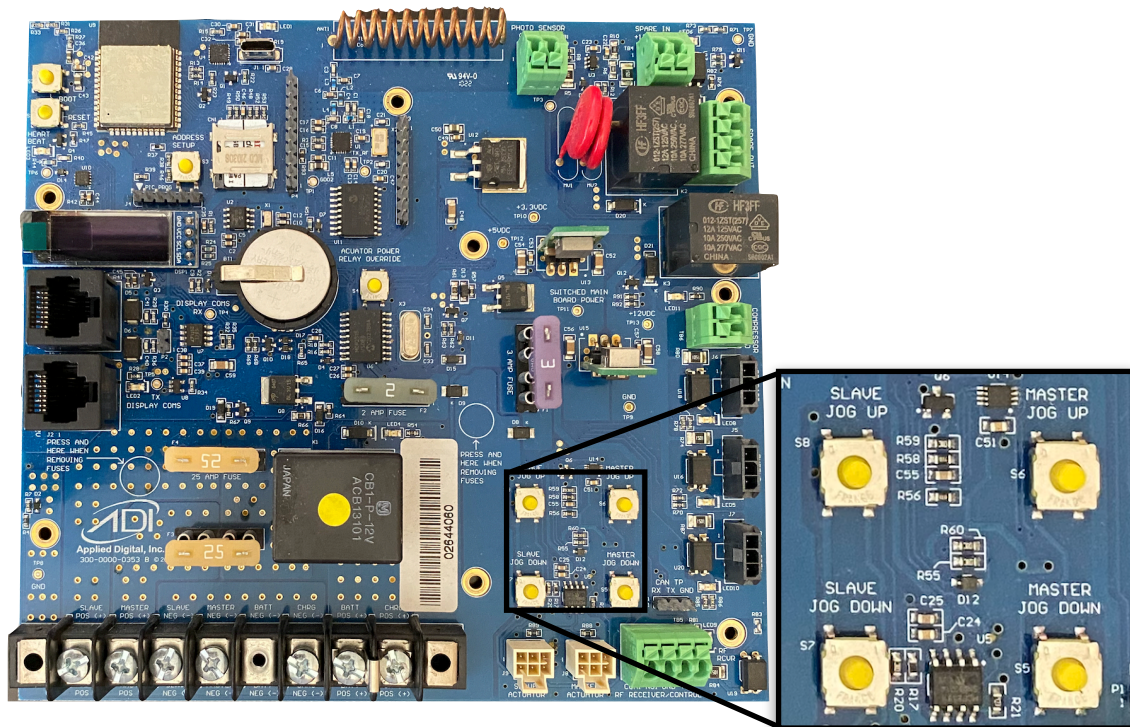

# TOP & BOTTOM SEALS

## Process 13 - Installing the Top & Bottom Seals

- A. With the door in the closed position check the top seal retainer's width to ensure proper fit. The retainer may need to be trimmed down slightly to fit correctly.
- B. Next, slide the grey top seal into the retainer completely and cut the seal to be 1/4" longer than the retainer on each side. Using pliers, crimp the retainer onto the seal at both ends to keep the seal from slipping during installation and normal usage.
- C. To fasten the seal and retainer to the top of the door, fully open the door, then fasten the retainer to the top frame member of the door panel using the provided self tapping screws. You'll want the retainer to be as far toward the exterior as it can be to ensure a proper seal when the door is closed. It may be necessary to mark the location before opening the door to install the retainer.
- D. To install the bottom seal, fully open the door and then hold the down button until the door reaches a height where you can easily access the bottom of the door panel.
- E. Position the bottom bulb seal as shown in the drawing, and affix the seal with screws placed every 12 inches or less. Once the entire seal has been affixed using the first row of screws, fold the seal over and affix the top portion of the seal between the main body of the seal and the drip edge. The drip edge should face the exterior of the door.
- F. Finally, you may trim off any excess bulb seal from the left and right of the door.

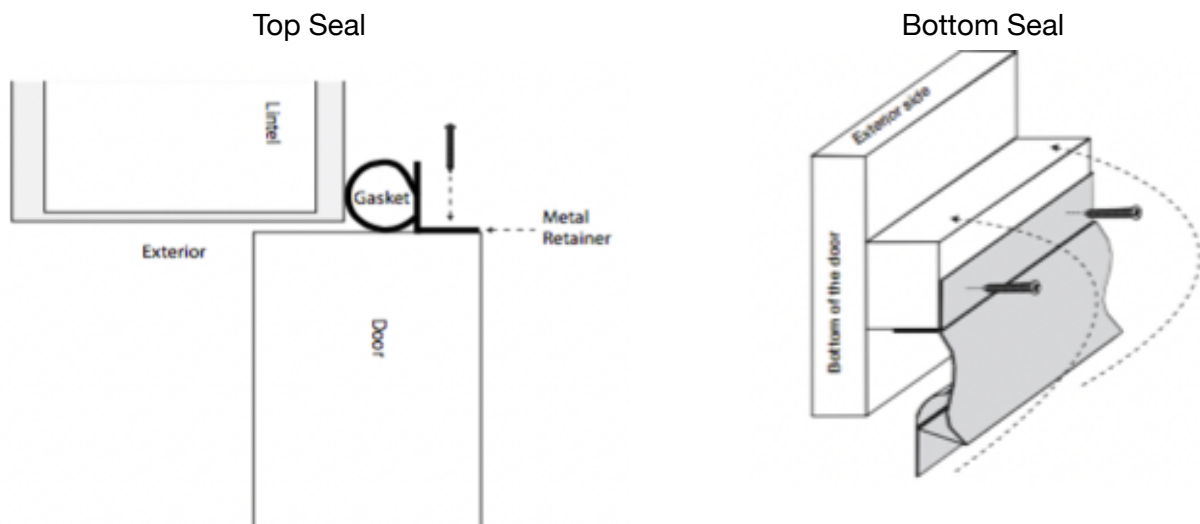

# THRESHOLD INSTALLATION

## Process 14 - Installing the Threshold

**NOTE: IF YOU MUST SPLICE THE THRESHOLD, MAKE SURE TO JOIN THE PIECES WHERE SCREWS WILL BE NO MORE THAN 8 INCHES FROM BOTH SIDES OF THE SPLICE.**

- A. To install the threshold first measure the opening between the left and right jambs and cut the threshold 4 inches longer than the measured opening.
- B. If required by the site conditions, you may need to cut a notch out of each side of the jamb. This notch is typically 2 inches by 2 inches, though you'll want to confirm that with each opening prior to cutting them. Seat these notches on the interior corners of the doorjamb and operate the door to make sure the bottom seal engages with the hump on the threshold and makes proper contact, while not inhibiting the door's movement.
- C. Once fitted, clean the area underneath the threshold and apply the provided adhesive to the interior and exterior parts of the underside of the threshold approximately 5/16" thick for the length of the threshold.
- D. Place the threshold into position, drill out the pilot holes using appropriate concrete or masonry bit, and tighten the fasteners securely.

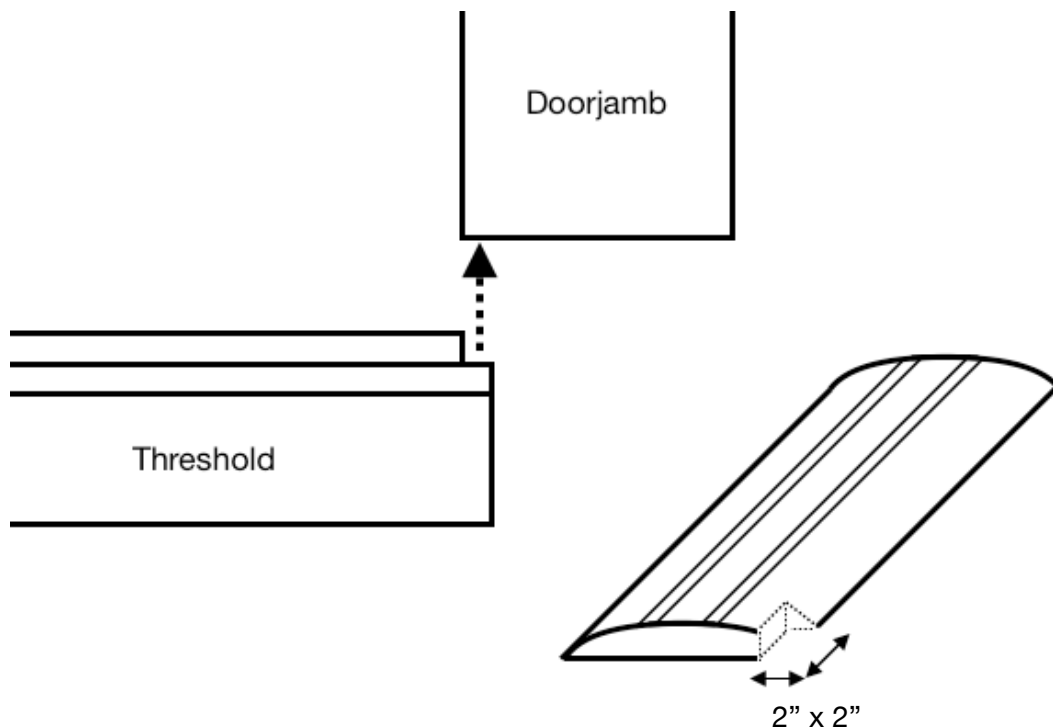

# OPERATION INSTRUCTIONS

## Operating Your EVO-Door

**NOTE: IF YOUR EVO-DOOR IS EQUIPPED WITH “WIND LOAD” PINS, THE OPENING SHOULD NEVER BE OPERATED WHILE THEY ARE IN PLACE. THESE ARE ONLY TO BE USED DURING HIGH WIND LOAD CONDITIONS TO SECURE THE DOOR. THEY ARE NOT INTENDED FOR USE AS A LOCK, BUT RATHER AS AN ADDITIONAL SAFETY FEATURE FOR USE IN PREPARATION OF HIGH WIND EVENTS SUCH AS SEVERE STORMS OR HURRICANES.**

- A. First ensure that wind load pins, if equipped, are not installed, and that nothing will impede the upward or downward function of the EVO-Door during its operation.
- B. Tap the touchscreen to access the controls, and if prompted enter your security code to unlock the door functions.
- C. To operate the door upwards, simply press the UP button.
- D. To operate the door downwards, press and hold the DOWN button until you reach the predefined down limit.